



# Lotus Lines

January/February 1990

6th Year of the Club ... 39th Year of the Marque

## Chairman's Ramblings - by John Daniels

Well here it is another new year. For some reason I don't feel like anything is really very new. I'm sitting here trying to think of new and exciting things for the club to do this year and I am pretty sure I was doing this same thing last year at about this time. One of my major unanswered questions is: What is the purpose of our club? The answers I come up with are as follows. 1) A social club, we seem to enjoy each others company and of course have the love of our cars in common. 2) A support group, we are able to share our problems/joys of owning Lotuses and offer advice and help to each other. 3) Sports car owners, we all enjoy driving and being involved with fine performance cars. 4) Events, we attend and get involved in sports car events. I'm sure there are other reasons for belonging, but these are the ones that come to mind right now as I sit here and desperately try to be creative with two nonoperating Lotus in the garage. If you have any thoughts along these lines, give me a call and let me know. We need more active involvement and definitely need some new ideas.

Our December meeting was held at the Bayside Lotus dealers in Seattle. The turnout was one of the best yet with about 24 people attending. Bud arranged for a Lotus representative to fly in for the meeting. He put on a fine slide presentation showing the factory and some of the procedures used in building both the new Elan and the Esprit. Bayside also furnished Lotus mugs to all that attended. I have made arrangements with Bayside to hold meetings there on a quarterly basis. The January meeting was hosted by Bob and Shari Crichton and resulted in three running Lotus. Nikki and I led a cruise consisting of one Ford (ours). This rather surprised me as Saturday was a beautiful sunny day. Maybe there is a message here that I am missing.

## Calendar of Events

Feb meeting - Sunday the 18th, Terry and Lezlee  
Mar meeting - Saturday the 31th, Bayside Lotus  
Apr meeting - Saturday the 21st, Jim Taylor  
May meeting - Sunday the 20th, Peter Miles  
Jun meeting - Saturday the 16th, Maury and John  
Jul meeting - Sunday the 21st?, Vashon run, Dave and Alice  
Aug meeting - Saturday the 18th, annual picnic, Terry and Lezlee  
Sep meeting - Saturday the 22nd, Bayside Lotus  
Oct meeting - ???  
Nov meeting - ???  
Dec meeting - ???



I'm happy to tell you that Bayside Lotus is very serious when they say they want to be involved and help in any way that they can. Tom, in the parts department, offered to assist me when I mentioned that I needed a front sway bar for my Seven. In a fairly short time he got back to me with the location and price for the parts that I needed. Including a 10% discount on the parts that are furnished by Lotus.

My buy of the month is a slight discount on the following items from Auto Gear in Redmond if we purchase at least five of any one item: enamel grill badges, lapel pins, decals or patches. His prices are in line with everyone else for these items to start with and somewhat of a bargain when discounted. If you are interested, give me a call and I will put together an order.

Once more I would like to thank Gary Wood for his time and effort in putting out the NewsLetter. Also I would like to extend a hearty welcome to Jim Taylor who graciously has taken over this task.

Last, but not least, I want to remind everyone that their annual dues of \$15.00 are now past due. We need them if you wish to continue to receive the Newsletter. To those that have already paid their dues, I thank you. When you send the club your dues, please fill in and include the information sheet at the same time.

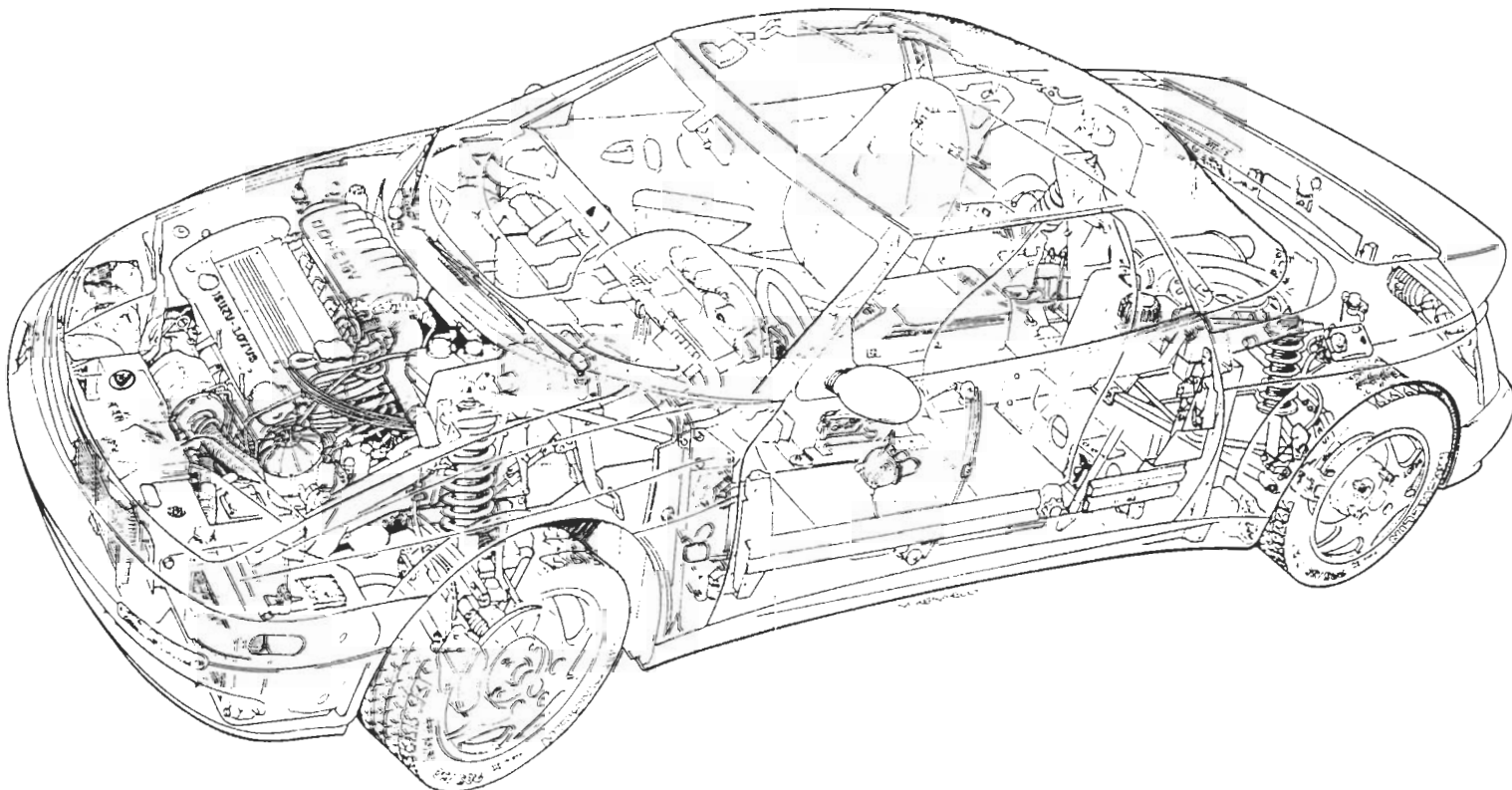

## 1990 CALENDAR by Terry Elmore

I recently attended, as a representative of the Evergreen Lotus Car Club, a meeting set up by Kevin Cobby and Rob Broderick of the MG Car Club. This gathering, attended also by representatives from a number of other local British car clubs, was called to compile a master calendar of 1990 club events. This will serve several functions:

- 1) Each club will have a readily-accessible listing of events being put on by the other clubs, including regular meetings, special events, tech sessions, tours, etc.
- 2) Each club will now know which events are open, for participation by others besides the sponsoring club- with dates, times and contact phone numbers.
- 3) For clubs such as ours, who don't have an entire year's events planned, such a calendar can help us avoid scheduling future events in conflict with other major events that club members may wish to attend. It also supplies us with an abundance of ideas that we can "borrow" for ourselves, either directly or with modification to suit our own group's needs.

A listing of our meeting locations for the next several months, along with the annual Evergreen Lotus picnic, which Lezlee and I will be hosting in August, along with information on the Camel Lotus Meet in Arizona in March, and the West Coast Lotus Meet in California in June, was provided for the Lotus entries on the Calendar. As soon as we receive the compiled listing, upcoming events of interest, especially those open events which we are allowed to participate in, will be passed along to the membership both through the newsletter and at the monthly meetings; major events, such as the out-of-state Lotus events will be covered with early information as soon as available, to enable you to make plans should you wish to attend. For example, we draw your attention to the two above-mentioned Lotus events, which have been discussed at the last two meetings and are covered in this issue- in particular, should you be interested in attending the Camel Lotus event in March, please note that your entry must be received in England by February 22nd. Entry forms for the West Coast Lotus Meet will be provided just as soon as they are available; there are already a number of Evergreen Lotus members planning to attend this event.

### WESTERN WASHINGTON ALL BRITISH MEET

After the meeting on the Master Calendar, reported above, I spoke with Rob Broderick on plans for this year's All British Meet, to be held again at Bellevue Community College.

This year will see a one-day event, to be held on Saturday, July 21st, the primary reason being that that is also the opening weekend for the Goodwill Games, and it was not possible to find a hotel willing to hold a block of room for the Meet participants; there also will not be a banquet for this year, for the same reason, and all awards will be given on the field at the conclusion of judging.

This year will see something different, in that we, along with the other participating clubs, will have both a financial commitment, and a prospect of a substantial financial return on that investment, in the Meet itself. The organizers will be selling shares in the Meet, to raise the operating costs needed; based on an estimate of the monies needed (there was a surplus from last year's meet, which has provided the initial funds to get things rolling) and the number of marque clubs participating, each club will probably be offered a chance to buy a "share" at a cost of around \$100; then, again based on last year's experience, the clubs will receive anywhere from \$300 to \$500 as return on their investment. Obviously, there are still details to be worked out, and none of this is official yet, but it looks like an excellent opportunity for a small club like ours, that doesn't have as many of the fund-raising opportunities that the larger groups do, to make a substantial increase in our treasury. More details as they are available.

As a result of our initial display last year, we have a number of ideas for our "new & improved, Mk. 2 display this year, which won't be divulged here (as other clubs see our newsletter, and we don't want them stealing our ideas while we steal theirs!), but these will be proffered at the next few meetings as we put together a committee to work on this year's display.

## CAMEL LOTUS OWNERS' PARTY

SCOTTSDALE/PHOENIX, ARIZONA MARCH 8, 1990

Included in this issue is an entry form for members interested in attending this event, to take place the Thursday before the US Grand Prix in Phoenix on March 11, the first race of the 1990 Formula 1 season. Hosted by Team Lotus sponsors, R J Reynolds, there will be a concours, and a dinner which will include as guests or honor the two new drivers for Camel Team Lotus, Derek Warwick and Martin Donnelly.

Initial information on this event included the stipulation that, to receive two entry tickets to the dinner, one would have to drive their Lotus to the event (with the exception on racing Lotus, which could be trailered). Most recent information received, via Mark Winston of Lotus Ltd. (thanks, Mark), is that this requirement has now been waived. You still must send your entry in before February 22nd, and Team Lotus will be verifying with the club that you are in fact a member in good standing of a Lotus club (so, pay your dues if you haven't done so yet for this year!)

R J Reynolds is expecting some 400-500 people at their party, how many of these will be driving Lotus is anybody's guess, but I suspect that even with the relatively short notice, there will be a fairly good turnout for the concours. They obviously are using their concours categories from their UK events- there are twelve classes, including one each for Lotus Sunbeams and Excels, which are liable to be rather sparsely populated (although GM did bring two Excels over, at least one of which had a Quad 4 dropped in it, but I believe one has already been shipped back).

*Chassis, powertrain and suspension layout.*

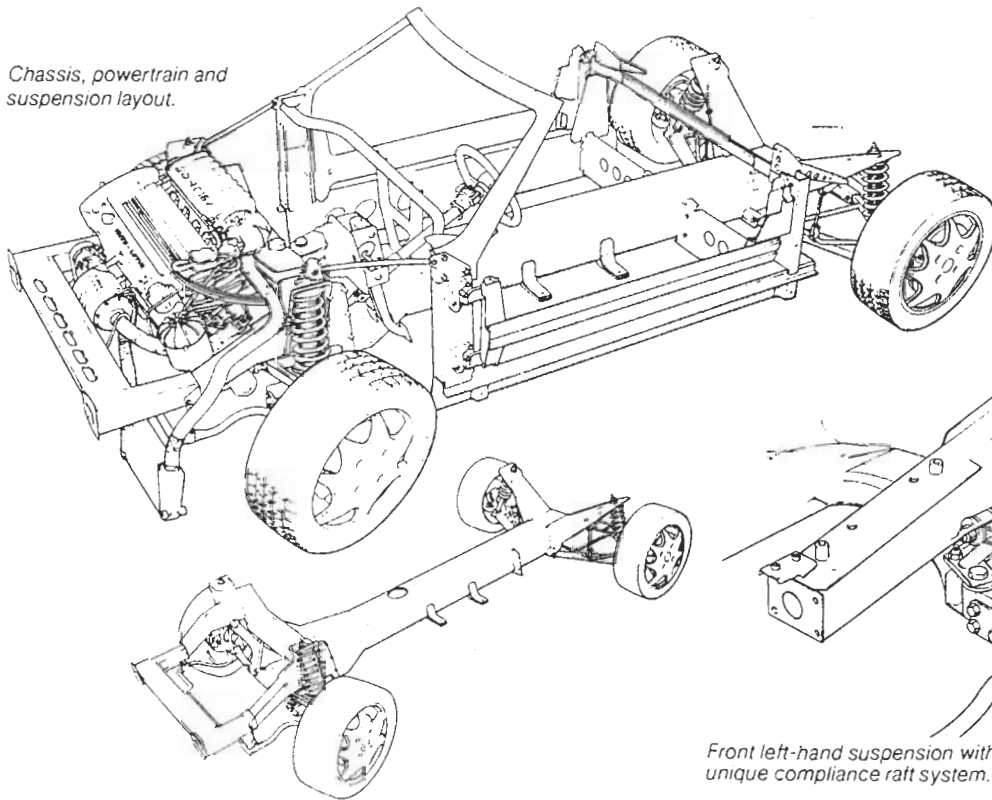

(1), the body laminating area has been re-facilitised to handle the low-profile resin system used in the Elan.

*Front left-hand suspension with Lotus' unique compliance raft system.*



# CAMEL LOTUS OWNERS' PARTY

SCOTTSDALE, PHOENIX, ARIZONA, MARCH 7/8 1990

Please use capital letters or type and return to Camel Team Lotus, Wymondham, Norfolk, NR18 9RS, United Kingdom by entry closing date of Thursday 22nd February 1990. Our confirmation of your entry which will be airmailed to you, will also confirm which of the two dates has been selected. If you wish to enter more than one car please send the information regarding the second/third vehicle(s) on another sheet of paper. Please note that invites will be despatched on a first come first served basis.

## ENTRANT

Given name:

First name:

Address:

City:

State

Zip code:

Telephone (home):

(business)

Name of Lotus club  
(if member):

Name of second guest (if any)  
accompanying you:

Signature:

## CAR

Type — Number or model:

License plate:

Color:

Year:

Class entered:  
(see attached)

Original or modified:

If the car has been altered in appearance or had mechanical changes, please give brief details:

**REMINDER: ENTRY CLOSING DATE IS FEBRUARY 22nd 1990**

CLUB TEAM LOTUS

KETTERINGHAM HALL, WYMONDHAM, NORFOLK NR18 9RS, ENGLAND

TELEPHONE: NORWICH (0603) 811662 (ansaphone) TELEX 975341. TELEFAX: (0603) 810467

meetings as we put together a committee to...

## WEST COAST LOTUS MEET 1990

This Meet has been mentioned at the past several club meetings, but we have delayed publishing the details in the Lotus Lines until now at the request of the Meet organizers while they were still trying to get the requisite site commitments. This is now done, so we can report to you that the West Coast Lotus Meet will take place on June 1,2, and 3 (Friday-Sunday), based at Sears Point Raceway which is located near Sonoma, California. While details on a number of the possible events at the WCLM are yet to be confirmed, and entry forms and Meet costs are not yet available, we want to provide you with as much information as we now have, so that if you're thinking of attending you can begin to make plans. Several Evergreen Lotus members have attended previous WCLMs (I have been to two, myself), and this year's Meet, particularly with the tie-in to the vintage races, promises to be the best one yet. I would like to highlight a few of the possible attractions at this event:

\*The hoped-for turnout of Lotus Formula 1 cars would be a real feast for the eyes and ears, showing some of the most significant models Chapman produced in his quest for seven Constructors titles (25,49,72,78 are all possible attendees); I look on this as a preview of what's in store when Lotus is finally the honored marque at the Monterey Historics, and we see the greatest-ever gathering of race and street Lotus in the US, an event not to be missed and one which I hope we'll see within the next three years.

\*The prospect of a half-, or full day on the track at Sears Point on Friday- as those who participated in Bayside's Track Day at SIR this year can attest, it's a lot of fun to turn hot laps in a Lotus, driving your car as it should be driven and under the proper conditions.

\*As Mike Ostrov, Secretary of Club Elite USA is involved in organizing the Meet as a GGLC member and vintage racer, I suspect we will see the largest gathering of early Elites in the US as an integral part of the Meet (again, a preview of Lotus at Monterey). Of the approximately 1000 Elites produced, at least 92 now reside in California, or nearly 10% of the original production- an amazingly high percentage, and while certainly not all of them are running or restored, the prospect of several dozen Elites gathered in one place is a sight not to be missed.

\*The Silverado Concours, which will take place on Sunday June 3rd, is the second-largest *Concours* on the West Coast; as 1990 is I believe the 25th anniversary of this event, they will no doubt put on an even greater show to commemorate the occasion.

\*Add to this all the other attractions of the Bay Area, if you are able to spend any time either before or after the WCLM itself to see something besides cars, cars, cars. . . . .

As more info comes to us, and in particular the entry forms, these will be available both at the meetings and via the Lotus Lines. In fact, I hope to have updated info available at the February meeting, so if this report has you thinking about a June get-away to Lotus Land, please do try to attend. We'll also have a lot of info on the many Northwest events on the calendar.

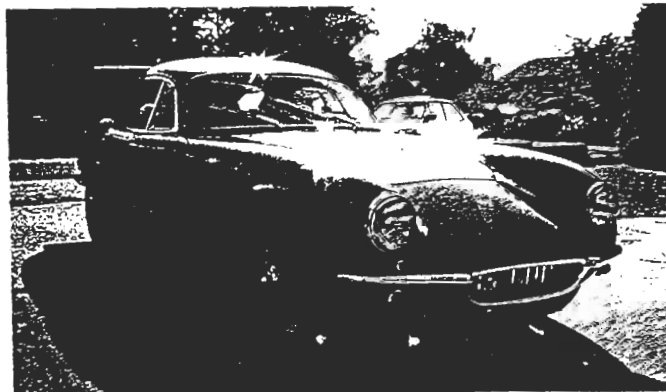

# Sunmark Announces...

A Full Automotive Upholstery Service ranging from repairing damaged and worn interiors to complete replacements. Our experienced staff can install a new vinyl interior, convertible top, or new carpeting. This addition to your vehicle will increase its value and your driving pleasure.

Stop by Our Showroom & see our complete line of sample materials to match your interior needs. We are proud to offer FREE ESTIMATES.

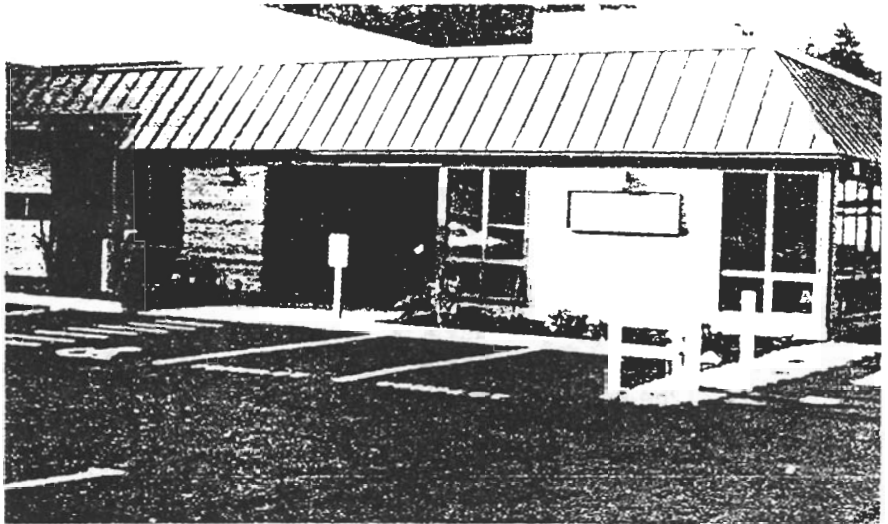

The home of SUNMARK - Contemporary Automobile Accessories, located just off I-405 in Kirkland

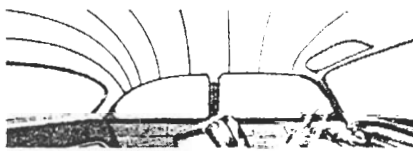

Headlinings



Landau Tops

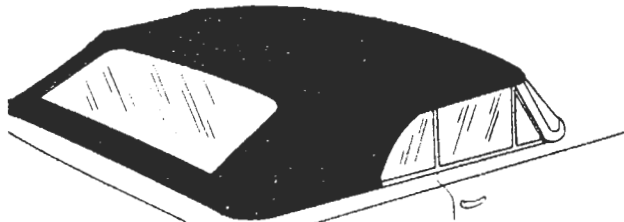

Convertible Tops



**AUTOMOTIVE INTERIORS**

**VISIT OUR SHOWROOM!**

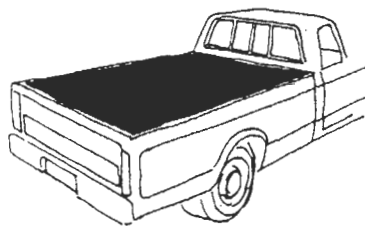
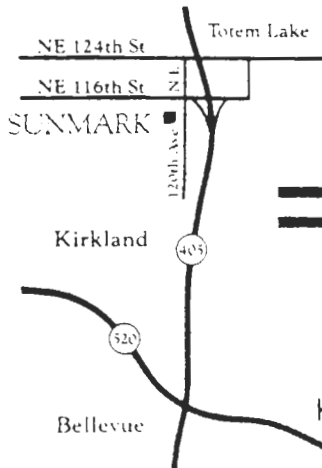

Tonneau Covers

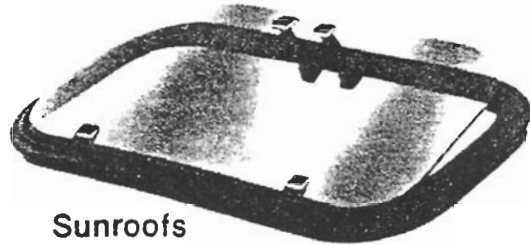

Sunroofs

**Sunmark Upholstery**  
 11435 - 120th N.E.  
 Kirkland, Washington 98033  
**821-2400**

**SIMPLY THE BEST**

**BEST PRICE, BEST SELECTION, BEST WARRANTY**

meetings as we put together a committee to...



ditor's WorkShop - by Jim Taylor

Welcome to LotusLines. Since this is my first time putting out a NewsLetter, I hope that all of you will bear with me while I learn exactly what it is I am supposed to be doing. When I volunteered for this job I thought "No problem, a couple of evenings to sort through and format the information and a couple more evenings to massage and print it", was I ever wrong. Gary must have put in at least two weeks worth of evenings to get this NewsLetter out every two months. Oh well, that's my one and only play for a little sympathy.

On to other things...

I am extending to each member of the Lotus Club an invitation to have some input into the Lotus Club's events and planning even if you don't normally show up. I will accept any ideas, written or over the phone, that you have about what you would like to see the Lotus Club doing, its direction, its purpose, questions or just general comments that you may want to air out. I will put them into the NewsLetter so that the Club can benefit from input by all the members instead of just the dedicated ones that normally show up at the meetings. Maybe we can get a few more members to show up at meetings once in a while if they can see that their input can make a difference. I know that John would love to have the members become more active and to express their ideas on the what the Lotus Club should or should not be doing. So at the expense of sounding pushy, if you live in the Puget Sound area, see what you can do about getting to at least one meeting or event a year.

On a permanent basis I am putting a section in the NewsLetter so that the voice of the members (seen or unseen) can be heard. Whether it's wanting to get together for a cruise, assisting with someone's "it's almost done" Lotus, asking questions, answering questions, whatever you think someone else in the Club might be interested in. I am asking for your input so that I can start this section by the next NewsLetter.

Any suggestions or ideas about the NewsLetter format or its content will be greatly appreciated. I am preparing the NewsLetter on an IBM compatible computer which has a hand scanner attached. This means that I can put pictures, sketches, diagrams or other printed materials directly into the newsletter along with information that you may have on floppy disk (3.5" or 5.25"). So, if you have any pictures or tidbits you would like to share with the rest of us, I can use the material. Anything you would like to send to me will be sent back when I am through if so desired.

On another topic, I am assisting Nikki Daniels in organizing a list of member's addresses, types of Lotus, etc which will be maintained on the computer. This will make it easier to accurately mail out the NewsLetter and to also supply each of you with a yearly list of the other members in the Club.

That's about it for this issue. I would like to acknowledge the use of the diagrams of the new Elan and the pictures which I picked up from Lotus World for use in the NewsLetter. For those of you that wish contact me, my mailing address and phone number are as follows:

Jim Taylor  
P.O.Box 229  
Issaquah, WA. 98027

Home phone: (206) 232-2237

If I'm not their, leave a message and I promise to get back to you as soon as I can, even if it's a long distance call.

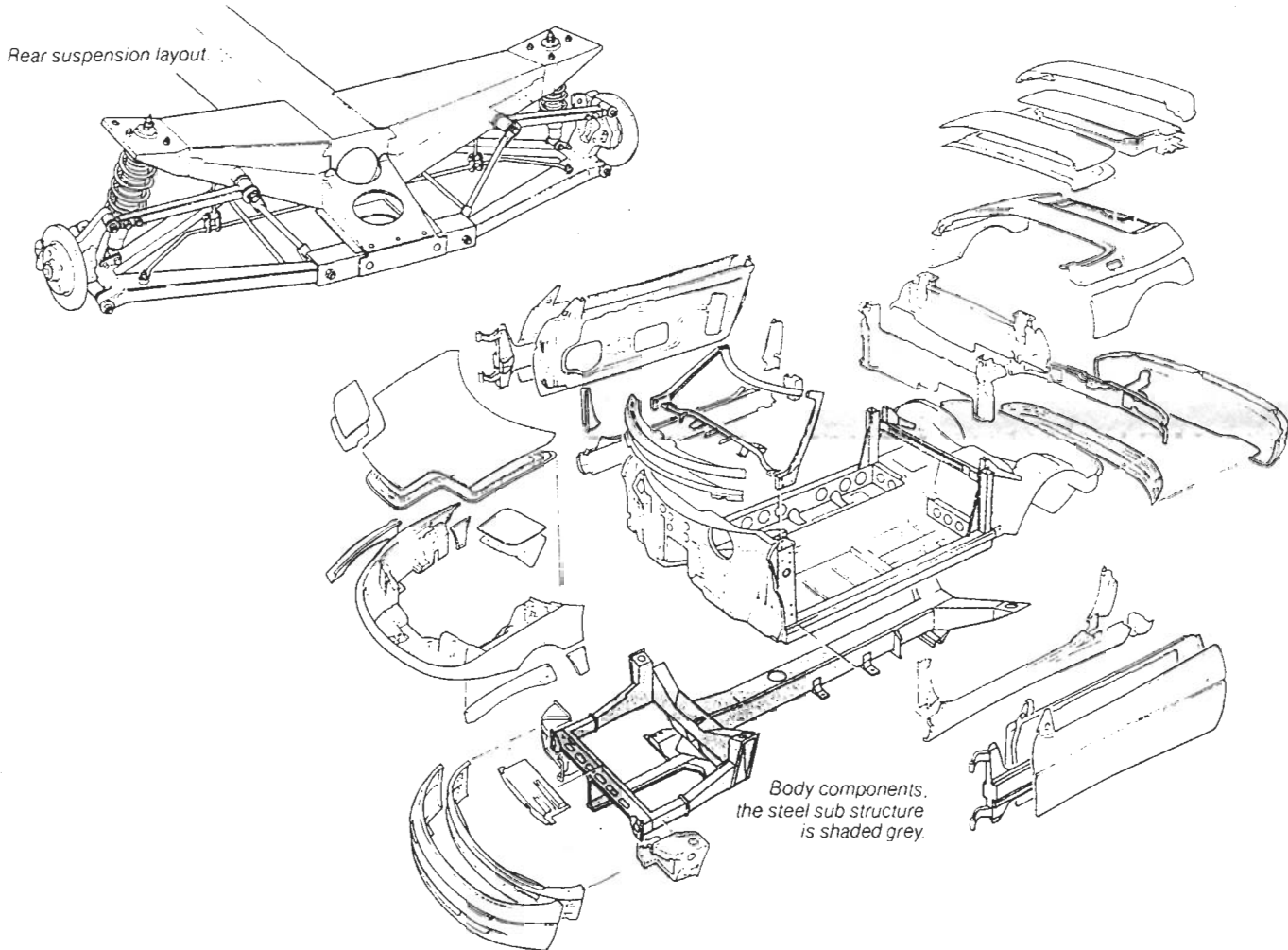

### Last minute Ramblings!!!

Puget Sound Tire will be sponsoring an open track day at S.I.R. on May 13th. It will cost \$40.00 per driver and your car will need to pass a safety and technical inspection. Professional driving instructors will be on hand and several tire manufacturers will be represented. It may be possible to test various tires on your car. Further information and applications may be available at the February or March meeting.

1990 DUES \$15 \* 1990 DUES \$15  
\* 1990 DUES \$15 \* 1990 DUES \$15  
\* 1990 DUES \$15 \* 1990 DUES \$15

Please complete the following for our records and mail in with your 1990 dues payment:

NAME ..... PARTNER .....  
ADDRESS .....  
CITY ..... STATE ..... ZIP .....  
HOME PHONE ..... WORK PHONE .....  
LOTUS CAR INFO (DATE, TYPE, SPECIAL INTEREST NOTES) .....  
.....  
.....  
.....  
.....

MAIL DUES AND INFO SHEET TO:  
**NIKKI DANIELS**  
11232 312 NE  
CARNATION WA 98014



Meeting Locations

February Meeting:

Sunday the 18th at 1:30

Terry and Lezlee Elmore  
3010 132nd Avenue SE  
Snohomish, WA.  
home phone: (206) 334-5768

March Meeting:

Saturday the 30th at 1:30

Bayside Lotus  
517 East Pike Street  
Seattle, WA.

(Parking in service  
area behind building)

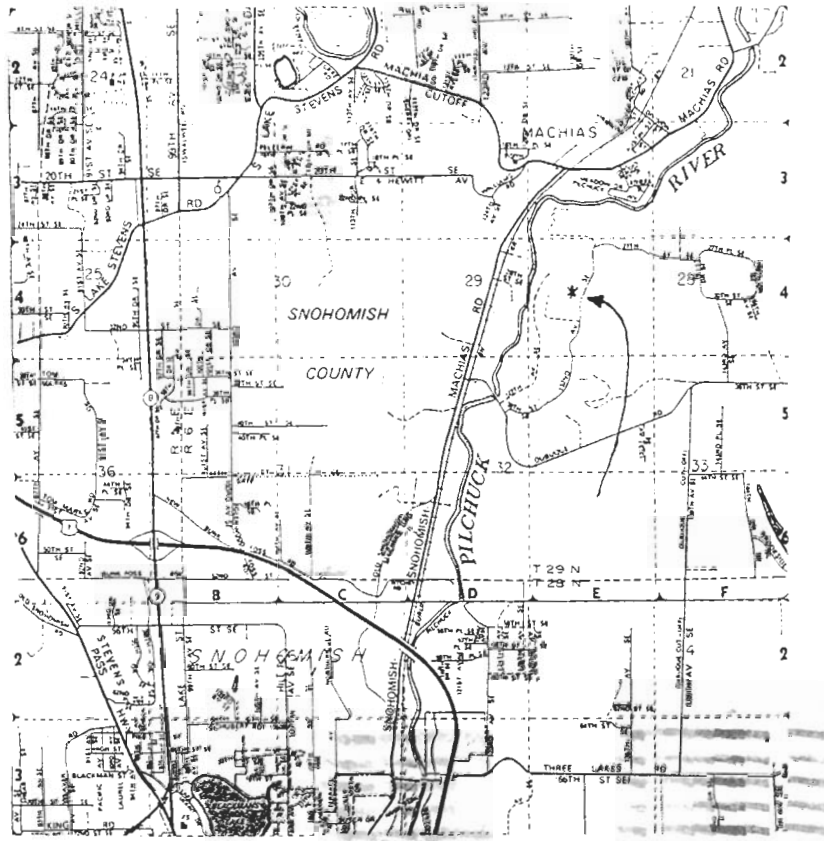

**Club Officers: John Daniels, Chairman, 788-2729 - Nikki Daniels, Membership  
Terry Elmore, Club Liaison, 334-5768 - Jim Taylor, NewsLetter, 232-2287**



**EVERGREEN LOTUS CAR CLUB**

**John Daniels, Chairman  
11232 312th NE  
Carnation, WA 98014**

**FIRST CLASS MAIL**

